



Braemar evaporative cooling
So clever, so quiet, so cool



Frank Seeley AM FAICD

Founder and Executive Chairman.

For more than 40 years, Seeley International has been creating world leading air conditioning products. In fact, in the 1970's, Seeley International pioneered all-plastic evaporative coolers, and since then it has gone on to deliver an ever growing number of world-first, innovative climate control solutions. It is now Australia's largest and most awarded air conditioning manufacturer.

Market leader in the design and manufacture of ducted heating and ducted and portable cooling systems, and renowned for its innovation, Seeley International's household brand names include Breezair, Braemar, Coolair, Convair and Climate Wizard.

With factories in Adelaide, South Australia, and Albury, New South Wales, when you buy one of these Seeley International products*, you can rest assured that you're buying an Australian made, quality product, backed by an Australian company with a long and remarkable history.



Seeley International's founder and Executive Chairman Frank Seeley AM FAICD at its Adelaide factory.

Braemar evaporative cooling – So clever, so quiet, so cool

Braemar evaporative air conditioners are brought to you by Seeley International, Australia's leading evaporative air conditioning and gas heating manufacturer. For over 50 years Braemar has been providing Australian families with superb high-performance heating and cooling products and has cemented its reputation as a trusted and innovative Australian company, especially so, since becoming part of the Seeley International group.

For outstanding quality, proven reliability and superior comfort that has stood the test of time, you can trust Braemar along with all of Seeley International's award winning brands.

Introducing a new range with superior cooling capacity – Braemar Supercool*.



You won't be disappointed, Braemar is... so clever, so quiet, so cool

NEW Braemar Supercool®

Braemar Supercool* provides up to an incredible 25% more cooling capacity than the standard range!

Braemar Supercool* is now available with the new MagIQtouch Controller – featuring advanced touch screen technology.



Supercool
DELIVERS UP TO 25% MORE COOLING

Some of Seeley International's awards...

BPN Sustainability Awards 2014

Finalist: Innovation of the year
MagIQtouch Controller

Sydney Design Awards 2014

Finalist: Product Design – Home
MagIQtouch Controller

BRW Momentum Mid-Market Leaders Awards

Winner: Best Mid-Market Business
(revenue \$100 million to \$250 million p.a.)
Seeley International

Australian Design Awards

Good Design® Selection
MagIQtouch Controller

United Nations Association of Australia World Environment Day Awards 2014 –

Winner: Swinburne University of Technology Excellence in Sustainable Product Design Award
Braemar "Super-Six" ducted gas heating

BRW Most Innovative Companies List

Number 23
Seeley International

Sydney Design Awards 2013 – Product Design

Winner: Housing & Building Awards
Braemar "Super-Six" ducted gas heating

Melbourne Design Awards 2013 – Product Design

Winner: Housing & Building Awards
Braemar "Super-Six" ducted gas heating

Business SA 2013 Export Awards

Winner: Environmental Solutions Award
Seeley International

Family Business Australia Award for Entrepreneurship 2013

Winner: Mr Frank Seeley AM FAICD



*For Convair, only the evaporative product range is made in Australia.

*Available exclusively from Seeley International dealers.



“The Braemar we installed is as quiet and efficient as promised! Wonderful!!!!”

Debbie-Marie, VIC

Why choose Braemar evaporative cooling



Comfort for the whole family

Built for the harshest Australian summer, Braemar evaporative air conditioning is a proven performer that won't let you down. For over 50 years Braemar has earned its reputation as the robust and reliable Australian made brand, by manufacturing world class evaporative air conditioning and ducted gas heating systems. Renowned for its “whisper-quiet” operation and engineering excellence, Braemar evaporative air conditioning has stood the test of time and will deliver fresh, natural and healthy super-cooling, year after year after year, so you can get on and enjoy summer.



A healthier choice

Evaporative cooling is a totally natural process filling your home with 100% fresh air – there couldn't be a healthier choice. Unlike refrigerated systems that can circulate stale recycled air, Braemar's Chillcel pads filter and clean the air which is not only great for general health and well being, but it is the ideal choice for allergy and asthma sufferers.*

By pumping fresh, cool air into your house and pushing hot, stale air out, Braemar evaporative cooling also operates as a ventilation system. Kitchen odours or stale air can be quickly and easily expelled from the home by turning the unit on or operating it in fan only mode.



Enjoy outdoor living

Summer is best enjoyed outdoors, but some air conditioning systems require you to shut all windows and doors and stay indoors to keep cool. With Braemar evaporative air conditioning you can enjoy indoor and outdoor living because evaporative cooling works best with the windows and doors open. This means kids can run inside and out all day without having to worry about closing doors ... and you can relax outside with a cool breeze streaming out through open windows and doors. Braemar gives you the best of both worlds – indoor and outdoor comfort.

*Always consult your medical practitioner for information regarding your specific condition.

Benefits of evaporative cooling:

- ≡ Delivers 100% fresh air
- ≡ Windows and doors can be left open
- ≡ Greatly reduces costs of staying cool
- ≡ Lower purchase and installation costs
- ≡ Guarantees fresh, natural, healthy “lifestyle” cooling
- ≡ Allergy free, asthma-safe environment*
- ≡ Replaces all of the air every few minutes
- ≡ Ensures full ventilation – drives out odours and stale air
- ≡ Never dries out the eyes and skin
- ≡ Helps keep insects and dust outside

“We are very happy with our evaporative cooling system. It made a big difference to what has been a long, hot summer. It was a very easy process and we would definitely recommend to others.”

Cath, VIC



Braemar saves you money

Energy efficiency

With soaring power prices, purchasing energy efficient products is becoming a key concern for all Australians. Choosing an energy efficient cooling system is no different. Fortunately your decision is made easy because evaporative air conditioning is, without doubt, the most energy and cost efficient way to cool your whole home.

The running of heating and cooling equipment accounts for around 38% of energy use in the average Australian home**, so choosing an energy efficient system can make a significant difference to your household energy consumption.

Evaporative air conditioning uses up to 85 percent less electricity than comparable refrigerated units.⁺ By choosing Braemar you are making the right choice to reduce energy consumption in your home.

Low running costs

Braemar's highly efficient system consumes less power than refrigerated units which means it will cost you less to run. Unlike refrigerated systems, a Braemar evaporative system won't send your electricity bill skyrocketing every time you turn it on. Braemar evaporative systems also cost much less to install than most other ducted systems.

Running Costs for Whole of Home Air Conditioning⁺

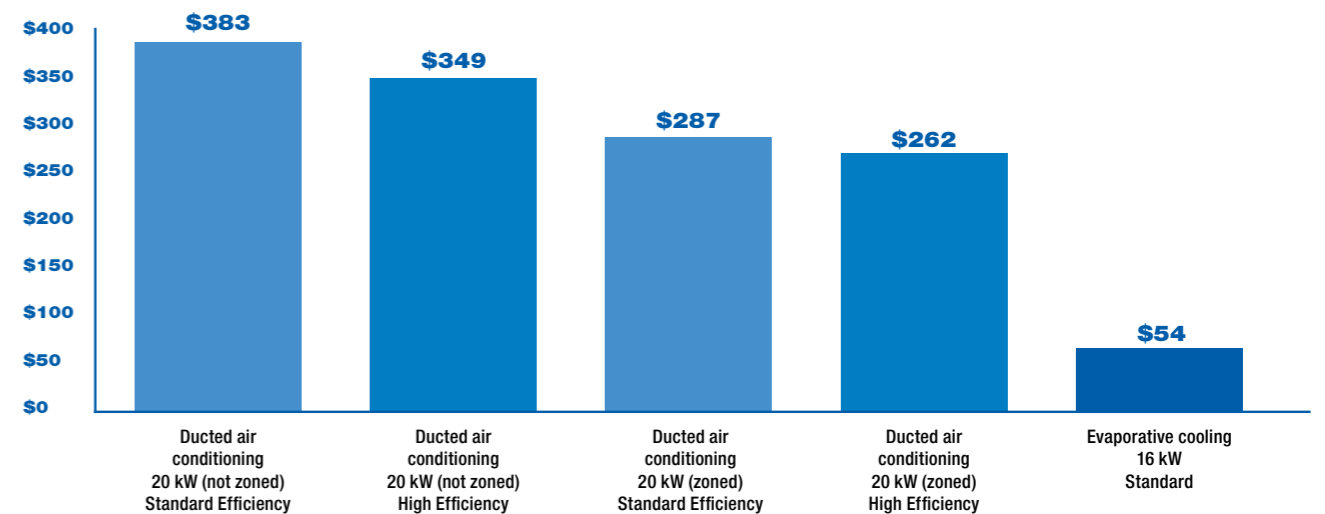

**Source: Australia's guide to environmentally sustainable homes, 'heating and cooling' technical manual. www.yourhome.gov.au, 2010.

⁺ Based on a 166m² home. Approximate cost per annum, based on 300 hours usage and a 60% duty cycle for air conditioners. Based on electricity tariff of 28 c/kWh. Note – evaporative coolers will also use water. Source: Sustainability Victoria, 'Cooling Running Costs', www.sustainability.vic.gov.au, 2013.

Braemar so clever, so quiet, so cool...

Whisper quiet cooling

Braemar is renowned for its whisper quiet operation. The secret is Braemar's state of the art, Stealth® fan that ensures a constant, even flow of air through the Chillcel pads. Braemar's experience of manufacturing over more than 50 years, coupled with its dedicated research and development team has delivered a truly unique fan system. The result is arguably the quietest axial air cooler available in the world. To ensure whisper quiet operation, a series of finely tuned blades located in the fan housing assist by straightening the air flow as it leaves the cooler. The advanced aerodynamic design uses only a small amount of energy to produce a cool, constant, quiet, welcoming breeze.

Superb engineering

Braemar's incredibly smart automatic drain valve and its AUTOWinterseal™ features, together reduce the need for seasonal maintenance*. There is no need to manually drain the unit or put a cover over it at the end of the summer. Braemar automatically empties its reservoir, leaving it clean and dry and closes off the air conditioning ducts to prevent cold draughts and heat loss in winter. Braemar was the first evaporative cooler to integrate the water distribution system into the design of the cabinet. The result is a robust free flow distributor that not only reduces the number of moving parts in the cooler, but also ensures an even and reliable water coverage of the Chillcel pads. The Braemar water distribution system won't block the flow of water to the pads and can't move out of place over time. That's clever!

Looks good – built to outlast

Braemar is clean, simple and modern. Its cabinet has been designed to blend into your roofscape.

Injection moulded from specially developed Permatuf® polymer, your Braemar won't rust, is UV resistant and will stand up to the harshest extremes of climate, year after year. Choose from four designer colours, specially created to suit heritage and modern homes alike.

- Quality
- Reliability
- Longevity

Powerful cooling

When it comes to delivering powerful cooling performance during the harshest Australian summer, Braemar has no peer. Every part of the Braemar cooler is designed to deliver maximum cooling performance with minimum energy and water consumption. With decades of air conditioning experience, superior design and advanced technology, Braemar coolers will deliver wonderfully cool comfort even during the hottest heatwaves.

Trusted Australian company

For over 50 years Braemar has manufactured quality evaporative cooling units and gas heating systems and is wholly owned by Seeley International. Our products are exclusively designed and built in Australia, especially for Australian conditions.

So, when it comes to performance, reliability, quality and safety, you know you are dealing with the market-leading specialist.

- Proudly Australian made
- 100% Australian owned
- Leading household brand for more than 50 years

* Seasonal maintenance is the time consuming routine required by some other units. Ask your dealer for a complete rundown. Seasonal maintenance does not replace regular maintenance of the unit as required for peak performance.

Better for the environment

The right choice for the environment

Evaporative coolers consume only a small proportion of the energy consumed by ducted refrigerated systems. By choosing energy-efficient appliances that consume less power, you can help the environment by reducing the amount of greenhouse gases generated by power stations. Evaporative coolers contain no harmful refrigerants. Many of the gases used in refrigerated air conditioners are synthetic gases like hydrofluorocarbons and some are also ozone depleting. Evaporative air conditioning produces less than one seventh of the volume of CO₂ of a standard ducted air conditioner.*

Water use

Braemar has advanced water saving technology designed to eliminate water waste. WATERmanager™ continuously monitors water quality electronically, replacing it only when mineral deposits exceed acceptable levels. The result is that Braemar air conditioners use the minimum amount of water resource to provide maximum cooling effect. Water is only discharged from the cooler when it reaches 2400 p.p.m. salinity. At this level it is suitable for many garden plants, including most lawns. Check with your nursery or council to confirm suitability for garden watering.

CO₂ Emissions for Whole of Home Air Conditioning (kg/yr)*

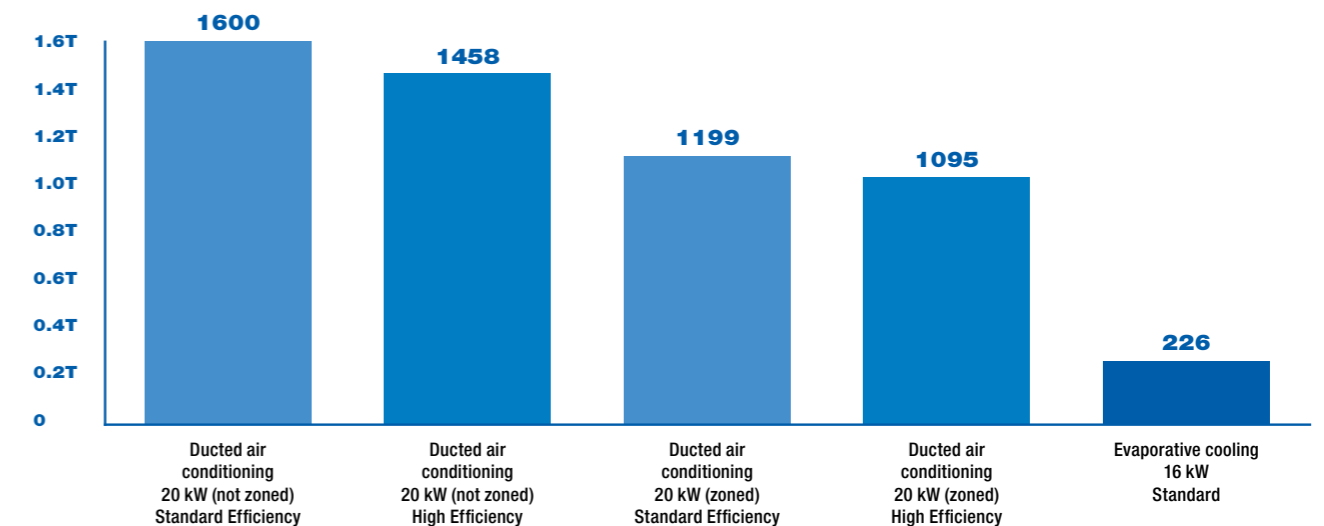

*CO₂ emissions based on 1.17 kg CO₂ e/kWhr electricity purchased from grid for Victoria. Source: National Greenhouse and Energy Reporting (Measurement) Determination 2008 – with amendments (schedule 1, part 6).



Whole of home cooling

Braemar evaporative coolers offer many advantages. One of the most impressive is that they cool entire homes without zoning. During a heat wave, you're not confined only to parts of your home as you may be with some refrigerated systems.

With Braemar, it's cool in every room of the house, day and night. Family life just carries on as normal, no matter how hot it gets outside. Everyone can play by day and sleep at night in cool comfort.

Add value to your home

An evaporative air conditioning system can cool your home more efficiently than any other system. However, a Braemar evaporative system can also add considerable value to your home for the simple reason that the name Braemar has long been synonymous with quality. The kind of quality that will serve you well for many years to come. And if you ever decide to sell, its high class durability will make selling your home all that much easier.

Braemar brings comfort to your whole home... not just one or two rooms.



Braemar Supercool features the new MagIQtouch Controller

– with advanced touch screen technology

With the MagIQtouch Controller, operating your Braemar Supercool[®] air conditioner is easy. It's smart, sophisticated and intuitive. And, its sleek, modern design will meld with the décor of almost all Australian homes.

You don't have to re-learn how to use this controller. Its technology is based on the same simplistic functions of other touch screens you're familiar with. It has intuitive user navigation, making the operating process simple.

With your lifestyle very much in mind, the MagIQtouch Controller together with your Braemar evaporative air conditioner, will make your home a haven on hot summer days.

Installation wizard

Upon installation of your Braemar Supercool[®] evaporative air conditioner and MagIQtouch Controller, your installer will be taken through an Installation Wizard. This ensures your Controller is set up correctly with an easy to follow, step-by-step navigation system specifically designed to make the installation process simple.

Program

If you like routine and want to "set and forget" a seven day program that suits your lifestyle, then Program Mode is for you.

Program Mode divides each day into four time periods. You decide when each of these periods begins and what you want your system to be doing.

And, Program Mode is flexible. If you leave or arrive home early, you can easily skip forwards to the next period. The program will take over again once the next time period begins.

Intuitive user navigation

There is no need to display advanced functionality if it isn't required. You have the choice to view simple or advanced displays.

In simple display you can set your mode and temperature and let the MagIQtouch Controller do the rest!

Or, if you would like access to more advanced features, by touching 'More' you can select manual temperature mode, manual fan speed mode, or program mode and access other settings.



MAGIQTOUCH
AIR SENSOR



Optional

Allows you to mount your MagIQtouch Controller in the most convenient place in your home, because the MagIQtouch Air Sensor detects the temperature, not the Controller.

MAGIQTOUCH
CONTROLLER

SEELEY
INTERNATIONAL

MagIQtouch Controller
warranty



Intuitive user navigation

Simple and advanced display options.



Installation wizard

Steps the installer through the commissioning process for optimum operation.



Manual mode

Manually control temperature and/or fan speed settings.



Program mode

Settable 7 day, 4 time periods program, customisable to suit your lifestyle (including a temporary over-ride function).



Energy saving night quiet mode

When turned on, the Energy saving night quiet mode automatically reduces fan speed during the night for even greater economy and whisper quietness.



Date and time

Date and time displays appear on all operation screens.



Child access lock

Select a pin code to control access to your Controller.



About appliance

Displays information about your appliance including serial number, model number, and software version.



Adjustable working temperature range

Customise the temperature range displayed on the slider.



Status information

When this option is turned on, a temporary information display window becomes accessible on all Manual and Program screens to aid in troubleshooting.



Inbuilt diagnostics

If a fault is detected in the system, a fault message dialogue box will appear with information about the fault and some options to resolve the issue.



Service

The Service menu contains information and functions to assist service personnel. Access is locked with a service pin code.



Settings

Change the Controller and system settings to suit your requirements.



Screen Brightness Adjustment

Adjust the brightness of the screen when in standby mode, to suit your home and preference.



Simple Mode Lock

Lock the display in simple mode if you don't want to worry about advanced operating modes.



Program skip forward/back functionality

Ability to skip forward on the program if you arrive or leave home earlier than usual.

*Available exclusively from Seeley International dealers.

*Available exclusively from Seeley International dealers.

Features and Benefits

Braemar Paradigm LCB and Supercool[®] LCS

Tornado[®] pump

Braemar's custom designed Tornado water pump provides exceptional reliability in the most extreme conditions.



Stealth[®] fan

Braemar's state of the art, Stealth fan is super quiet in operation and ensures a constant, even whisper of air through the Chillcel pads. The advanced aerodynamic design uses only a small amount of energy to produce a constant, cool, quiet, welcoming breeze.



Chillcel[®] pads

Made from a special cellulose material, these long-life pads were independently tested to help establish maximum saturation levels and therefore, maximum cooling efficiency. The pads are essentially self-cleaning. Dust and pollen is captured on the pads and washed away into the sump below by the flow of water.



Free flow water distributor

A world patented water distribution system delivers continuous, even water coverage to the Chillcel pads, ensuring maximum cooling effect continues throughout the long, hot, summer days and nights.



AutoWinterseal[™]

This Braemar feature makes life so much easier. Whenever the system is not in use, the AUTOWinterseal automatically closes off the air conditioning ducts. This prevents dust and unpleasant odours from entering the house, while preventing cold draughts and heat loss in winter.



Totally enclosed Tropic proof motor

The Braemar air conditioner is second-to-none in design and manufacture. As the heart of the unit, the totally enclosed tropic proof motor has been put through rigorous performance tests to ensure longer term performance and incredible reliability. Being variable speed, the motor gives you maximum control over your family's comfort level at all times.



WaterManager[™] system

This unique feature keeps the system clean and ensures you save precious water by minimising water loss through dumping. This is achieved by constantly measuring the salinity of water in the tank and dumping it only when necessary, to ensure clean and efficient operation. This means you will not waste water like other evaporative systems, and you can save over 9,000 litres compared to a basic bleed system. This will save you lots of money as well as water.



Automatic drain valve

Your Braemar system doesn't require seasonal maintenance*** at the beginning and end of each season because your unit is fitted with an automatic drain valve. This specially programmed valve keeps your cooling system clean and operating at maximum efficiency, while using the minimum amount of water. When your system is not in use, the valve automatically empties the reservoir, leaving it clean and dry.



***Seasonal maintenance is the time consuming routine required by some other units. Ask your dealer for a complete run down. Seasonal maintenance does not replace regular maintenance of the unit as required for peak performance.



Optional extras:

Firewall Auto-seal

- Helps prevent ember attack in bushfires
- Metal flap that isolates the cooler from the duct work
- When fitted, the Braemar unit complies with
 - Bushfire Attack Level rating BAL-LOW through to BAL-29 (AS3959)
 - The Building Code of Australia.



Firewall ember screen

- Helps guard against ember attack in bushfires
- Made from non-combustible mesh
- Maximum aperture of 2 mm
- Can be fitted to existing cooler pad frames
- Minimal reduction of air flow of 5 %.

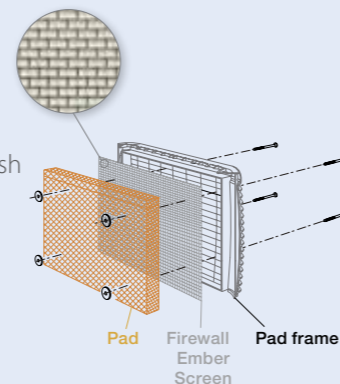

Warranty

Every single Braemar unit is made from premium grade materials and its components fully tested before and after assembly. It is also supported by a comprehensive factory-backed warranty.

While our engineering and quality control procedures are so good that we don't think you'll ever need to use it, our warranty is there for your protection... and ongoing peace of mind.

The Braemar Paradigm and Supercool[®] Series are backed by a 7 year* comprehensive warranty. There is also a 10 year structural warranty and a 25 year Permatuf Cabinet warranty.



*Available exclusively from Seeley International dealers.

*Available exclusively from Seeley International dealers.

Why choose Braemar Supercool*?

Enjoy superior cooling this summer with new Braemar Supercool*!

This incredible new range has super thick Chillcel pads, producing up to 25% more cooling when compared to the standard range.

Braemar Supercool* is now available with new MagIQtouch Controller – featuring advanced touch screen technology.



Supercool
DELIVERS UP TO 25% MORE COOLING

The Braemar Paradigm and Supercool* Ranges

Braemar offers two exciting product ranges, the proven reliability and superior comfort of the long standing Paradigm range, and now, the incredible new Supercool* range, that delivers up to 25% more cooling!



	Model	Dimensions			Weight	Nominal motor power	Cooling Capacity**	Controller	
		Length	Width	Height				MagIQtouch	Paradigm
		mm	mm	mm	kg	W	kW		
Paradigm	LCB 250	1150	1150	685	78	340	7.3		✓
	LCB 350	1150	1150	685	79	430	8.5		✓
	LCB 450	1150	1150	835	87	600	11.7		✓
	LCB 550	1150	1150	835	89	950	12.5		✓
Supercool*	LCS 280	1150	1150	685	78	340	9.2	✓	
	LCS 380	1150	1150	685	79	430	9.9	✓	
	LCS 480	1150	1150	835	87	600	14.6	✓	
	LCS 580	1150	1150	835	89	950	15.5	✓	

*Available exclusively from Seeley International dealers.

**The Paradigm models have the same cooling output as previous years, however, our new NATA accredited testing laboratory has enabled us to be much more accurate when calculating cooling capacities and these latest cooling capacities will be reflected in the specifications of all Seeley International models as well as in the test results of all our competitors' models. The above data was drawn from Meridian Test Laboratory's test analysis. The testing was performed by a NATA accredited laboratory to the requirements of the Australian standard AS2913-2000 "Evaporative Air Conditioning Equipment." Achievable with ambient 38 °C DB, 21 °C WB, room temperature 27.4 °C.

Features and Benefits

MagIQtouch Controller – Braemar Supercool*



Features	Benefits	Braemar Paradigm LCB series	Braemar Supercool* LCS series
MagIQtouch Controller®	Smart, sophisticated and intuitive touch screen controller.		✓
Paradigm Controller	Easy to use wall controller.	✓	
Stealth® fan	Stealth fan is super quiet in operation and ensures a constant, even whisper of air through the Chillcel pads.	✓	✓
Fan speed	1 to 10 speed.	✓	✓
Fan only	Operate the cooler in Fan Only mode (no water) to flush fresh air through the home and expel odours.	✓	✓
Totally enclosed Tropic proof motor	Being variable speed, the motor gives you maximum control over your family's comfort level at all times.	✓	✓
AutoWinterseal™	Automatic sealing system to reduce draughts and heat loss in winter.	✓	✓
Pre-wet function	When turned on, the Pre-wet Function will run the pump for a few minutes to allow the pads to be fully saturated before the fan is switched on, ensuring that only cooled air enters the home.	✓	✓
Drain and dry	Automatically drains water from the tank when the system is not in use to prevent algae growth and obviate seasonal maintenance.	✓	✓
WaterManager™ system	WaterManager monitors water quality to reduce consumption, minimise waste and salt deposits and eliminate unnecessary dumping of water. It keeps the system clean and ensures you save precious water by minimising water loss through dumping.	✓	✓
Manual drain	Turns the cooler off and drains the tank.	✓	✓
Pad flush	Ideal for bushfire prone areas, 'Pad flush' turns the cooler off and runs the pump continuously or for a set time.		✓
Auto re-start (optional)	After power outage, your cooler will automatically restart.		✓

*Available exclusively from Seeley International dealers.



“ We have been very satisfied with Braemar and don't know if we could go back to the old days of no air conditioning. The energy efficiency of the cooler is also a top priority for us. ”

Donna, VIC

Which model do I need?



Your Braemar dealer is the expert... they'll help you choose a system that's exactly right for you.

Your accredited Braemar dealer is well qualified to help you select the correct Braemar evaporative air conditioner for your home.

Braemar Paradigm series wall controller

Ease of use

The Braemar Paradigm Series wall controller puts climate control at your fingertips. It's so easy to use. You set the comfort level you want on the controller and the Braemar unit does the rest.

You can choose from four different control modes to cool your entire home the way you want.

- **Auto:** In Auto mode, the system monitors room temperature and automatically increases or decreases fan speed to maintain your selected cooling level.
- **Manual:** This mode allows you to determine the fan speed you want. Increase it for greater cooling and turn it down as the day declines.
- **Timer:** Use this mode to program the system to switch on or off at any time over a 24 hour period.
- **Fan:** Fan mode allows you to use the system as a ventilator. When a cool change arrives, turn on the fan only and pump Mother Nature's cool change through your home.



CompuComfort™ sizing system

For a smarter design CompuComfort™ is another brilliant example of Seeley International innovation.

Exclusive to your Seeley International dealer, the intelligent CompuComfort™ design program uses a unique web application to accurately profile your home's key architectural aspects. CompuComfort™ considers a variety of factors such as solar and thermal gains, insulation values; in so doing it ensures the optimum system is specified for your unique requirements.

COMPUCOMFORT™



Seeley International

Seeley International is Australia's largest air conditioning and ducted gas heating manufacturer and a global leader in developing ingenious, energy-efficient cooling and heating products.

Our vision is to lead the world in creating climate control solutions which continue to be highly innovative, of premium quality and inspirational in their delivery of energy-efficiency.

But it's more than just a vision... it's a way of life!

A commitment to innovation and excellence is at the heart of all that we do. Our success in delivering on that commitment has been recognised by our many awards and our expanding global presence. Seeley International now exports to well over 120 countries. Not bad for a company that started out in 1972 in the garage of its founder and Executive Chairman, Frank Seeley AM FAICD, who was named South Australian of the Year for 2011!



Haier*

convair*

coolair*

Braemar
Tudor Romeo

*Haier air conditioning products are proudly distributed by Seeley International throughout Australia.

To locate your nearest accredited Braemar dealer
call **1300 360 815** or go to **braemar.com.au**.

Please visit **braemar.com.au** to find out
more about our current promotions.*

*Promotions are seasonal and do not run at all times of the year.

Seeley International Pty Ltd

ABN 23 054 687 035

112 O'Sullivan Beach Road, Lonsdale, South Australia 5160

Phone (08) 8328 3850 Fax (08) 8328 3951

Email marketing@seeleyinternational.com www.seeleyinternational.com

Information in this brochure was correct at the time of preparation. E & OE